



PART NUMBER 0638L-15A  
 ITEM NAME 638 NM LASER (DIODE; PM FIBER)

## PRODUCT DATASHEET



### DESCRIPTION

638 nm PM fiber-coupled laser module is dedicated to scanning fluorescent microscopy. Red radiation is used to excite many commercial fluorescent dyes, like 'Alexa Fluor'. The robust and compact package is designed for the highest reliability and performance.

By default, this type of laser is built with FC/PC connector, but other fiber terminations are available upon request. Details about non-standard connector and the fiber used with it should be discussed with the Integrated Optics sales team.

### SPECIFICATIONS

Specifications updated: 28 December 2022

Parameter	Minimum Value	Typical Value	Maximum Value
Central Wavelength, nm	635	638	641
Longitudinal modes	-	Multiple	-
Spectral line width FWHM, nm	0.02	0.7	1
Output power, mW	-	100 <sup>1</sup>	-
Power stability, % (RMS, 8 hrs)	0.01	0.05 <sup>2</sup>	0.2
Power stability, % (peak-to-peak, 8 hrs)	0.05	0.25 <sup>3</sup>	1
Intensity noise, % (RMS, 20 Hz to 20 MHz)	0.05	0.25 <sup>4</sup>	0.6
Transversal modes	-	TEM00	-
M <sup>2</sup> effective	-	1.05	1.1
Polarization direction	-	Aligned within the slow axis of the PM fiber and the key position. <sup>5</sup>	-
Polarization extinction ratio (from PM fiber), dB	20	27	40
Control interface type	-	UART <sup>6</sup>	-
Operation mode	-	APC (CW)	-
Modulation bandwidth, MHz	-	10 <sup>7</sup>	-
Input voltage, VDC	4.8	5	5.3
External power supply requirement	-	+5 V DC, 1.5 A	-
Dimensions, mm	-	50 x 30 x 18 <sup>8</sup>	-
Fiber Length, m	0.95	1	1.1
Heat-sinking requirement, °C/W	-	1	-
Optimum heatsink temperature, °C	15	20	30

### TYPICAL SPECTRUM

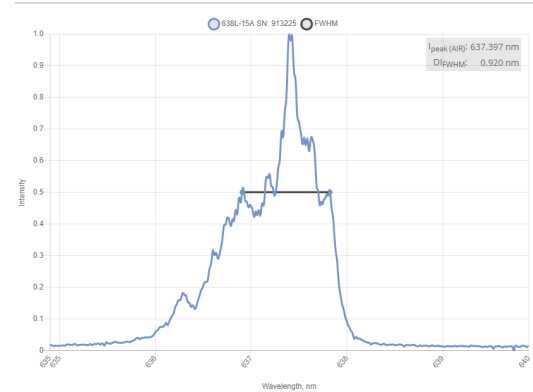

Typical spectrum of 0638 nm diode laser. Measured with 20 pm resolution.

### TYPICAL NEAR FIELD

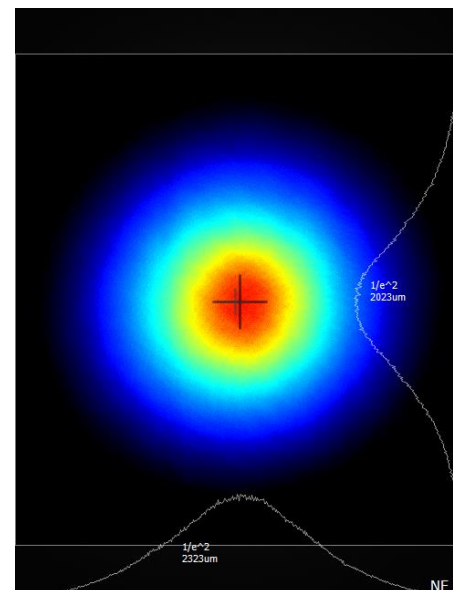

Warm up time, mins (cold start)	0.1	0.5	1
Temperature stabilization	-	Internal TEC	-
External fan control	-	No <sup>9</sup>	-
Overheat protection	-	Yes	-
Storage temperature, °C (non-condensing)	-10	-	50
Net weight, kg	0.1	0.12	0.14
Max. power consumption, W	0.4	2	10
Warranty, months (op. hrs)	-	14 (10000) <sup>10</sup>	-
RoHS	-	Yes	-
CE compliance	-	- General Product Safety Directive (GPSD) 2001/95/EC - (EMC) Directive 2004/108/EC	-
Laser Safety Class	-	3B	-
OEM lasers are not compliant with	-	IEC60825-1:2014 (compliant using additional accessories)	-
Country of origin	-	Lithuania	-

## DRAWING

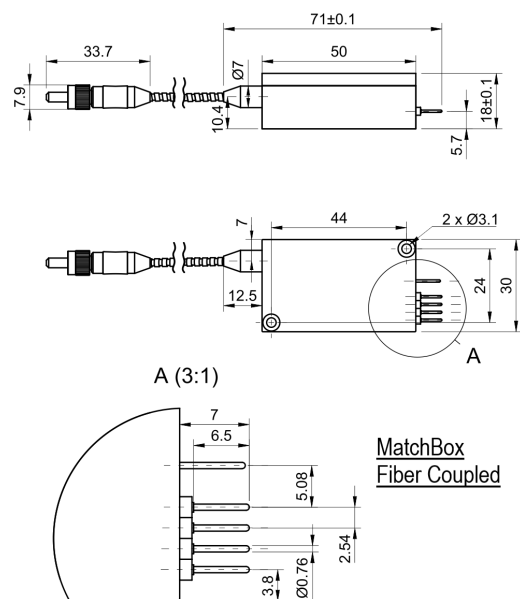

<sup>1</sup> The optical power can be tuned from virtually 0% to 100%. However, other specifications, such as central wavelength, power stability, noise, polarization ratio, beam shape, quality and circularity are not guaranteed at power levels other than factory preset power. Significantly worse power stability is to be expected at very low power levels, e.g. <3% from specified nominal power.

<sup>2</sup> The long term power test is carried out at constant laser body temperature (+/-0.1 °C) using an optical power meter with an input bandwidth of 10 Hz. The actual measurement rate has a period of about 20 seconds to 1 minute.

<sup>3</sup> The long term power test is carried out at constant laser body temperature (+/-0.1 °C) using an optical power meter with an input bandwidth of 10 Hz. The actual measurement rate has a period of about 20 seconds to 1 minute.

<sup>4</sup> Noise level is measured with a fast photodiode connected to an oscilloscope. The overall system bandwidth is from 2 kHz to 20 MHz.

<sup>5</sup> With possible error of up to ±5°.

<sup>6</sup> Break-out-boxes AM-C8 and AM-C3 can be used for conversion of UART communication to either USB or RS232.

<sup>7</sup> TTL digital modulation up to 10 MHz.

<sup>8</sup> Excluding control interface pins and an output window/fiber assembly.

<sup>9</sup> This function can be enabled in hardware only if the fast modulation option is disabled. The customer must specify this before ordering the laser.

<sup>10</sup> Whichever occurs first. The laser has an integrated operational hours counter.

Note: Product specifications are subject to change without prior notice to improve reliability, function or design or otherwise.