



PART NUMBER 0830T-41A
 ITEM NAME 830 NM TUNABLE LASER

PRODUCT DATASHEET



DESCRIPTION

This 830 nm laser features a **tunable** single-longitudinal-mode (SLM) and operates in multiple transversal modes. It is used mainly in industrial applications of Raman spectroscopy, where a high-power single-frequency operation is needed without the necessity of sharp focusing.

The transversal modes are distributed in one row, thus the fast axis can be focussed with $M^2 \sim 1.3$, while the slow axis has multiple modes and its focusability is poor - theoretically, it can be focussed to a width of $\sim 50 \mu\text{m}$.

This laser is a Volume Bragg Grating (VBG) stabilized diode laser, which is distinguished by high electrical efficiency and exceptional wavelength stability.

Note:

In optical systems with strong back-reflections (e.g. more than 10%), the laser must be protected by using an optical isolator with at least 20 dB isolation. Typical applications include interferometry, confocal microscopy (especially working with reflective samples), etc. Failure to comply with these requirements will render the warranty void for cases of COD (Catastrophic Optical Damage) of laser diode facets.

SPECIFICATIONS

Specifications updated: 7 February 2024

Parameter	Minimum Value	Typical Value	Maximum Value
Central wavelength, nm	829.7	830	830.3
Longitudinal modes	-	Narrow Spectrum	-
Spectral line width FWHM, pm	-	50	100
Output power, mW	-	450 ¹	-
Side-mode suppression ratio (SMSR), dB	-	50 ²	-
Power stability, % (RMS, 8 hrs)	-	0.1 ³	0.5
Power stability, % (peak-to-peak, 8 hrs)	-	2 ⁴	3
Intensity noise, % (RMS, 20 Hz to 20 MHz)	-	0.3 ⁵	1
Transversal modes	-	Multiple	-
Beam diameter at aperture (1/e ²), mm	-	0.5 x 2	-
Polarization direction	-	Unpolarized ⁶	-
Control interface type	-	UART ⁷	-
Operation mode	-	APC (CW)	-
Modulation bandwidth, MHz	-	N/A ⁸	-
Input voltage, VDC	4.8	5	5.3
External power supply requirement	-	+5 V DC, 1.5 A	-
Dimensions (WxDxH), mm	-	50 x 30 x 18 ⁹	-
Beam height from the base, mm	9.9	10.4	10.9
Heat-sinking requirement, °C/W	-	1	-
Optimum heatsink temperature, °C	15	20	30
Warm up time, mins (cold start)	0.2	1	2
Temperature stabilization	-	Internal TEC	-

TYPICAL SPECTRUM

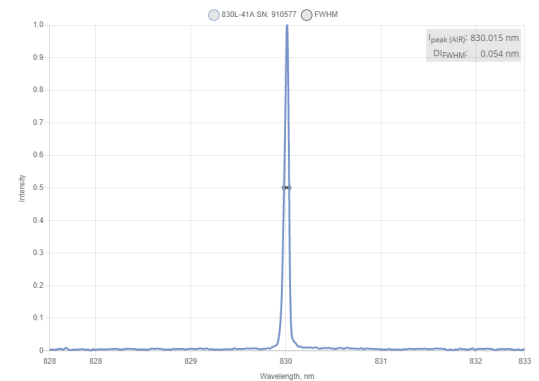

Typical spectrum of 0830T-41A nm diode laser. Measured with 10 pm resolution.

DRAWING

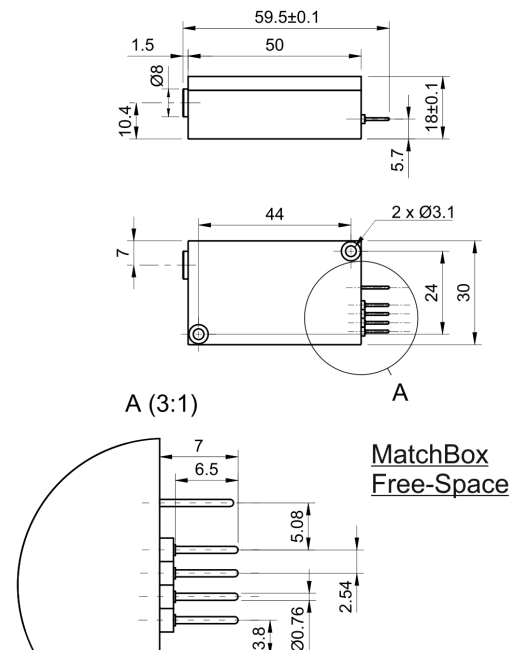

Overheat protection	-	Yes	-
Storage temperature, °C (non-condensing)	-10	-	50
Net weight, kg	0.1	0.12	0.14
Max. power consumption, W	0.4	2	10
Warranty, months (op. hrs)	-	14 (10000) ¹⁰	-
RoHS	-	Yes	-
CE compliance	-	- General Product Safety Directive (GPSD) 2001/95/EC - (EMC) Directive 2004/108/EC	-
Laser safety class	-	4	-
OEM lasers are not compliant with	-	IEC60825-1:2014 (compliant using additional accessories)	-
Country of origin	-	Lithuania	-
Tunability range, nm	-	-0/+1	-

¹ The output power of SLM lasers shall not be tuned and SLM performance is not guaranteed at power ratings other than factory preset. However, the power setting capability is not disabled. External attenuators are recommended instead.

² Without a clean-up filter installed.

³ The long term power test is carried out at constant laser body temperature (+/-0.1 °C) using an optical power meter with an input bandwidth of 10 Hz. The actual measurement rate has a period of about 20 seconds to 1 minute.

⁴ The long term power test is carried out at constant laser body temperature (+/-0.1 °C) using an optical power meter with an input bandwidth of 10 Hz. The actual measurement rate has a period of about 20 seconds to 1 minute.

⁵ Noise level is measured with a fast photodiode connected to an oscilloscope. The overall system bandwidth is from 2 kHz to 20 MHz.

⁶ For lasers without integrated optical isolators.

⁷ Break-out-boxes AM-C8 and AM-C3 can be used for conversion of UART communication to either USB or RS232.

⁸ SLM lasers shall not be modulated - use external modulators instead.

⁹ Excluding control interface pins and an output window/fiber assembly.

¹⁰ Whichever occurs first. The laser has an integrated operational hours counter.

Note: Product specifications are subject to change without prior notice to improve reliability, function or design or otherwise.