

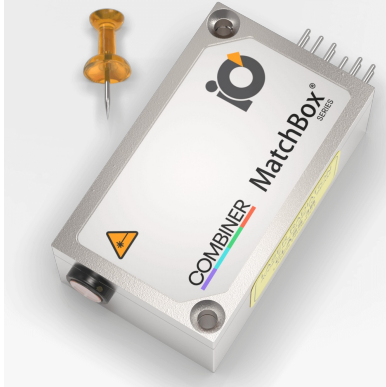

PART NUMBER 40A-48A-52A-64A-10  
 ITEM NAME MULTI-WAVELENGTH LASER

## PRODUCT DATASHEET



### DESCRIPTION

Revolutionize your research in life sciences and fluorescence applications with our cutting-edge 4-Wavelength Laser Combiner. This compact powerhouse seamlessly integrates four distinct wavelengths into a single housing, providing unmatched convenience without sacrificing performance. Now available with custom beam shaping.

#### Features:

- Four wavelengths
- Plug-and-play
- Single user interface for all 4 wavelengths

#### Advantages:

- Space-saving design
- No optics realignment
- Remote PC control

## SPECIFICATIONS

Specifications updated: 14 March 2024

Parameter	Minimum Value	Typical Value	Maximum Value
Output power, mW	-	405 nm - 120 488 nm - 40 520 nm - 80 638 nm - 130 <sup>1</sup>	-
Wavelength tolerance, nm	400 480 515 635	405 488 520 638	410 495 530 641
Longitudinal modes	-	Multiple	-
Spectral line width FWHM, nm	-	1	2
Power stability, % (RMS, 8 hrs)	-	0.2 <sup>2</sup>	1
Power stability, % (peak-to-peak, 8 hrs)	-	1 <sup>3</sup>	3
Intensity noise, % (RMS, 20 Hz to 20 MHz)	-	0.5 <sup>4</sup>	1
Transversal modes	-	TEM <sub>00</sub>	-
Control interface type	-	UART <sup>5</sup>	-
Operation mode	-	ACC (CW)	-
Modulation bandwidth, MHz	-	10 <sup>6</sup>	-
Input voltage, VDC	-	9	12
External power supply requirement	-	+9 V DC, 1.5 A 7	+12 V DC, 1.5 A
Dimensions (WxDxH), mm	-	50 x 30 x 18 <sup>8</sup>	-
Beam height from the base, mm	-	10.4	-
Heat-sinking requirement, °C/W	-	<0.5	-
Optimum heatsink temperature, °C	-	25	-

## DRAWING

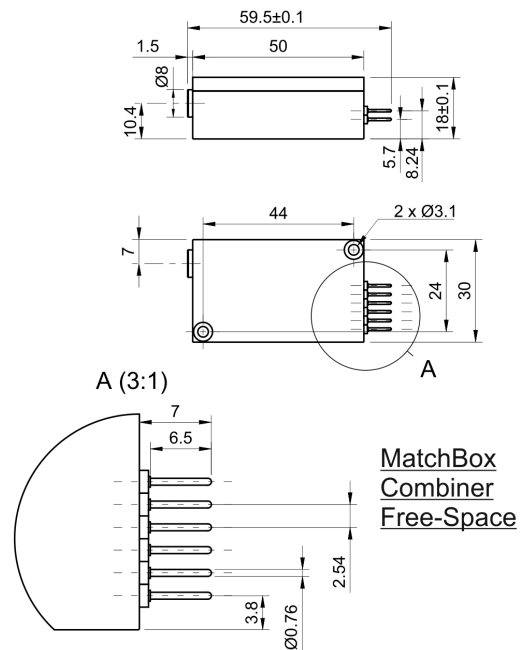

Warm up time, mins (cold start)	<b>0.1</b>	<b>0.5</b>	<b>1</b>
Temperature stabilization	-	Internal TEC	-
Overheat protection	-	Yes	-
Storage temperature, °C (non-condensing)	<b>-10</b>	-	<b>50</b>
Net weight, kg	-	<b>0.3</b>	-
Power consumption, W	-	<b>2<sup>9</sup></b>	<b>18</b>
Warranty, months (op. hrs)	-	<b>14 (10000)<sup>10</sup></b>	-
RoHS	-	Yes	-
CE compliance	-	- General Product Safety Directive (GPSD) 2001/95/EC - (EMC) Directive 2004/108/EC	-
OEM lasers are not compliant with	-	IEC60825-1:2014 (compliant using additional accessories)	-

<sup>1</sup> The optical power can be tuned from virtually 0% to 100% by changing the driving current of the laser diodes. However, other specifications, such as central wavelength, power stability, noise, polarization ratio, beam shape, quality, and circularity are not guaranteed at power levels other than factory preset power. Significantly worse power stability is to be expected at very low power levels, e.g. <3% from specified nominal power.

<sup>2</sup> The long term power test is carried out at constant laser body temperature (+/-0.1 °C) using an optical power meter with an input bandwidth of 10 Hz. The actual measurement rate has a period of about 20 seconds to 1 minute.

<sup>3</sup> The long term power test is carried out at constant laser body temperature (+/-0.1 °C) using an optical power meter with an input bandwidth of 10 Hz. The actual measurement rate has a period of about 20 seconds to 1 minute.

<sup>4</sup> Noise level is measured with a fast photodiode connected to an oscilloscope. The overall system bandwidth is from 2 kHz to 20 MHz.

<sup>5</sup> The break-out-box AM-C9 can be used for conversion of UART communication to USB.

<sup>6</sup> TTL digital modulation up to 10 MHz.

<sup>7</sup> If the break-out-box AM-C9 is used, a PD (Power Delivery) type of power supply can be used.

<sup>8</sup> Excluding control interface pins and an output window/fiber assembly.

<sup>9</sup> For single enabled wavelength.

<sup>10</sup> Whichever occurs first.

Note: Product specifications are subject to change without prior notice to improve reliability, function or design or otherwise.