



PART NUMBER 40A-48A-52A-64A-16  
 ITEM NAME DIODE LASER COMBINER; SMA PORT (405 NM, 488 NM, 520 NM, 638 NM)

## PRODUCT DATASHEET



### DESCRIPTION

It is a wavelength combiner featuring 4 laser diodes integrated within ultra compact 'Matchbox 2' housing. Classical dichroic mirror combining technique is used in combination with our proprietary micro-optics assembly to make this system both economical and compact. All optics and electronics are fitted into the ultra compact 'Matchbox' housing. An easy to use PC interface and separate TTL inputs allows full control over the individual wavelengths.

This wavelength combiner provides up to four wavelengths, which are standard for use in Life Sciences, Food sorting, Metrology and Medical applications. Unit combines wavelengths into a MM output fiber. An easy to use PC interface allows full control over the individual wavelengths.

#### Features:

- Four wavelengths
- Plug-and-play
- Single user interface for all 4 lasers

#### Advantages:

- Space saving design
- No optics realignment
- Remote PC control

#### Applications:

- Wide field and Fluorescence Microscopy
- Flow cytometry
- Food sorting and quality
- Particle characterization

## SPECIFICATIONS

Specifications updated: 1 October 2020

| Parameter                                | Minimum Value | Typical Value   | Maximum Value |
|--|---------------|---|---------------|
| Output power, mW                         | -             | 405 nm - 100<br>488 nm - 40<br>520 nm - 70<br>638 nm - 100 <sup>1</sup> | -             |
| Wavelength Tolerance                     | -             | +/-5 nm   | -             |
| Longitudinal Modes                       | -             | Multiple  | -             |
| Spectral line width FWHM, nm             | -             | 0.7   | 1.2           |
| Fiber Core Diameter                      | -             | 105 µm, 200 µm, 400 µm  | -             |
| Power stability, % (RMS, 8 hrs)          | -             | 0.2 <sup>2</sup>  | 1             |
| Power stability, % (peak-to-peak, 8 hrs) | -             | 0.2 <sup>3</sup>  | 1             |
| Noise, % (RMS, 20 Hz to 20 MHz)          | -             | 0.8 <sup>4</sup>  | 2             |
| Transversal Mode                         | -             | multimode (top-hat-like)  | -             |
| Control Interface                        | -             | UART <sub>5</sub>   | -             |
| Operation Mode                           | -             | ACC (CW)  | -             |
| Modulation bandwidth, MHz                | -             | 10 <sup>6</sup>   | -             |
| Input voltage, VDC                       | -             | +9  | -             |

## DRAWING

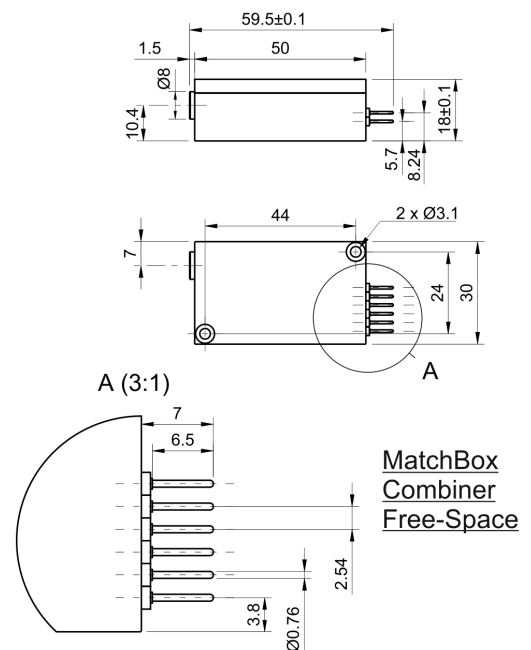

|  |     |  |                    |
|--|-----|--|--------------------|
| External Power Supply Requirement        | -   | +9 V DC, 1.5 A   | +12 V DC,<br>1.5 A |
| Dimensions, mm                           | -   | 50 x 30 x 18 <sup>7</sup>  | -                  |
| Heat-sinking requirement, °C/W           | -   | <0.5   | -                  |
| Optimum heatsink temperature, °C         | 15  | 20   | 30                 |
| Warm-up Time, min (Cold Start)           | 0.1 | 0.5  | 1                  |
| Temperature Stabilization                | -   | Internal TEC   | -                  |
| Overheat Protection                      | -   | Yes  | -                  |
| Storage temperature, °C (non-condensing) | -10 | -  | 50                 |
| Net weight, kg                           | -   | 0.2  | -                  |
| Power consumption, W                     | -   | 2  | -                  |
| Warranty, months (op. hrs)               | -   | 14 (10000) <sup>8</sup>  | -                  |
| RoHS                                     | -   | Yes  | -                  |
| CE Compliance                            | -   | - General<br>Product Safety<br>Directive<br>(GPSD)<br>2001/95/EC -<br>(EMC) Directive<br>2004/108/EC | -                  |
| OEM Lasers Are Not Compliant With        | -   | IEC60825-<br>1:2014<br>(compliant using<br>additional<br>accessories)                                | -                  |

<sup>1</sup> The optical power can be tuned from virtually 0% to 100%. However, other specifications, such as central wavelength, power stability, noise, polarization ratio, beam shape, quality and circularity are not guaranteed at power levels other than factory preset power. Significantly worse power stability is to be expected at very low power levels, e.g. <3% from specified nominal power.

<sup>2</sup> The long term power test is carried out at constant laser body temperature (+/-0.1 °C) using an optical power meter with an input bandwidth of 10 Hz. The actual measurement rate has a period of about 20 seconds to 1 minute.

<sup>3</sup> The long term power test is carried out at constant laser body temperature (+/-0.1 °C) using an optical power meter with an input bandwidth of 10 Hz. The actual measurement rate has a period of about 20 seconds to 1 minute.

<sup>4</sup> Noise level is measured with a fast photodiode connected to an oscilloscope. The overall system bandwidth is from 2 kHz to 20 MHz.

<sup>5</sup> The break-out-box AM-C9 can be used for conversion of UART communication to USB.

<sup>6</sup> TTL digital modulation up to 10 MHz.

<sup>7</sup> Excluding control interface pins and an output window/fiber assembly.

<sup>8</sup> Whichever occurs first.

Note: Product specifications are subject to change without prior notice to improve reliability, function or design or otherwise.