



PART NUMBER 40A-52A-64A-78A-11  
 ITEM NAME DIODE LASER COMBINER; FREE-SPACE (405NM, 520NM, 638NM, 785NM)

## PRODUCT DATASHEET



### DESCRIPTION

A widely configurable 4-wavelength dichroic combiner featuring precisely co-aligned optical paths in a free-space output configuration. All optics and electronics fitted into the ultra compact 'Matchbox' housing. This particular configuration provides up to four wavelengths, which are standard for use in Life Sciences, Food, Metrology and Medical applications. An easy to use PC interface and separate TTL inputs allows full control over the individual wavelengths.

#### Features:

- Four wavelengths
- Plug-and-play
- Single user interface for all 4 lasers

#### Advantages:

- Space saving design
- No optics realignment
- Remote PC control

#### Applications:

- Wide field and Fluorescence Microscopy
- Flow cytometry
- Food sorting and quality
- Particle characterization

## SPECIFICATIONS

Specifications updated: 1 October 2020

Parameter	Minimum Value	Typical Value	Maximum Value
Output power, mW	-	405 nm- 120 520 nm- 80 638 nm- 130 785 nm- 150 <sup>1</sup>	-
Wavelength Tolerance, nm	-	+/-5	-
Longitudinal Modes	-	Multiple	-
Spectral line width FWHM, nm	-	1	2
Power stability, % (RMS, 8 hrs) at 20 °C	-	0.2 <sup>2</sup>	1
Noise, % (RMS, 20 Hz to 20 MHz)	-	0.5 <sup>3</sup>	1
Transversal Mode	-	TEM00	-
Polarization direction	-	Horizontal	-
Polarization contrast	405 nm - 50 520 nm - 50 638 nm - 10 785 nm - 10	405 nm - 300 520 nm - 300 638 nm - 100 785 nm - 100	-
Control Interface	-	UART <sup>4</sup>	-
Operation Mode	-	ACC (CW)	-
Input voltage, VDC	8	9	12
External Power Supply Requirement, V	-	+9 V DC, 1.5 A <sup>5</sup>	+12 V DC, 1.5 A
Dimensions, mm	-	50 x 30 x 18 <sup>6</sup>	-

## DRAWING

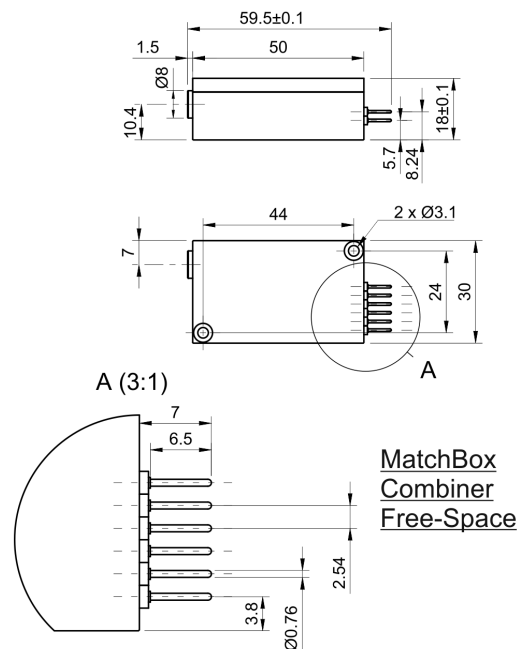

Beam height from the base, mm	-	10.4	-
Heat-sinking requirement, °C/W	-	<0.5	-
Optimum heatsink temperature, °C	-	20	25
Warm-up Time (Cold Start)	-	< 1	2
Temperature Stabilization	-	Internal TEC	-
Overheat Protection	-	Yes	-
Storage temperature, °C (non-condensing)	-	-	-
Net weight, kg	-	0.3	-
Power consumption, W	-	2 <sup>7</sup>	18
Warranty, months (op. hrs)	-	14 (10000) <sup>8</sup>	-
RoHS	-	Yes	-
CE Compliance	-	- General Product Safety Directive (GPSD) 2001/95/EC - (EMC) Directive 2004/108/EC	-
OEM Lasers Are Not Compliant With	-	IEC60825-1:2014 (compliant using additional accessories)	-

<sup>1</sup> The optical power can be tuned from virtually 0% to 100% by changing the driving current of the laser diodes. However, other specifications, such as central wavelength, power stability, noise, polarization ratio, beam shape, quality, and circularity are not guaranteed at power levels other than factory preset power. Significantly worse power stability is to be expected at very low power levels, e.g. <3% from specified nominal power.

<sup>2</sup> The long term power test is carried out at constant laser body temperature (+/-0.1 °C) using an optical power meter with an input bandwidth of 10 Hz. The actual measurement rate has a period of about 20 seconds to 1 minute.

<sup>3</sup> Noise level is measured with a fast photodiode connected to an oscilloscope. The overall system bandwidth is from 2 kHz to 20 MHz.

<sup>4</sup> Break-out-boxes AM-C8 and AM-C3 can be used for conversion of UART communication to either USB or RS232.

<sup>5</sup> If the break-out-box AM-C9 is used, a PD (Power Delivery) type of power supply can be used.

<sup>6</sup> Excluding control interface pins and an output window/fiber assembly.

<sup>7</sup> For single enabled wavelength.

<sup>8</sup> Whichever occurs first.

Note: Product specifications are subject to change without prior notice to improve reliability, function or design or otherwise.